

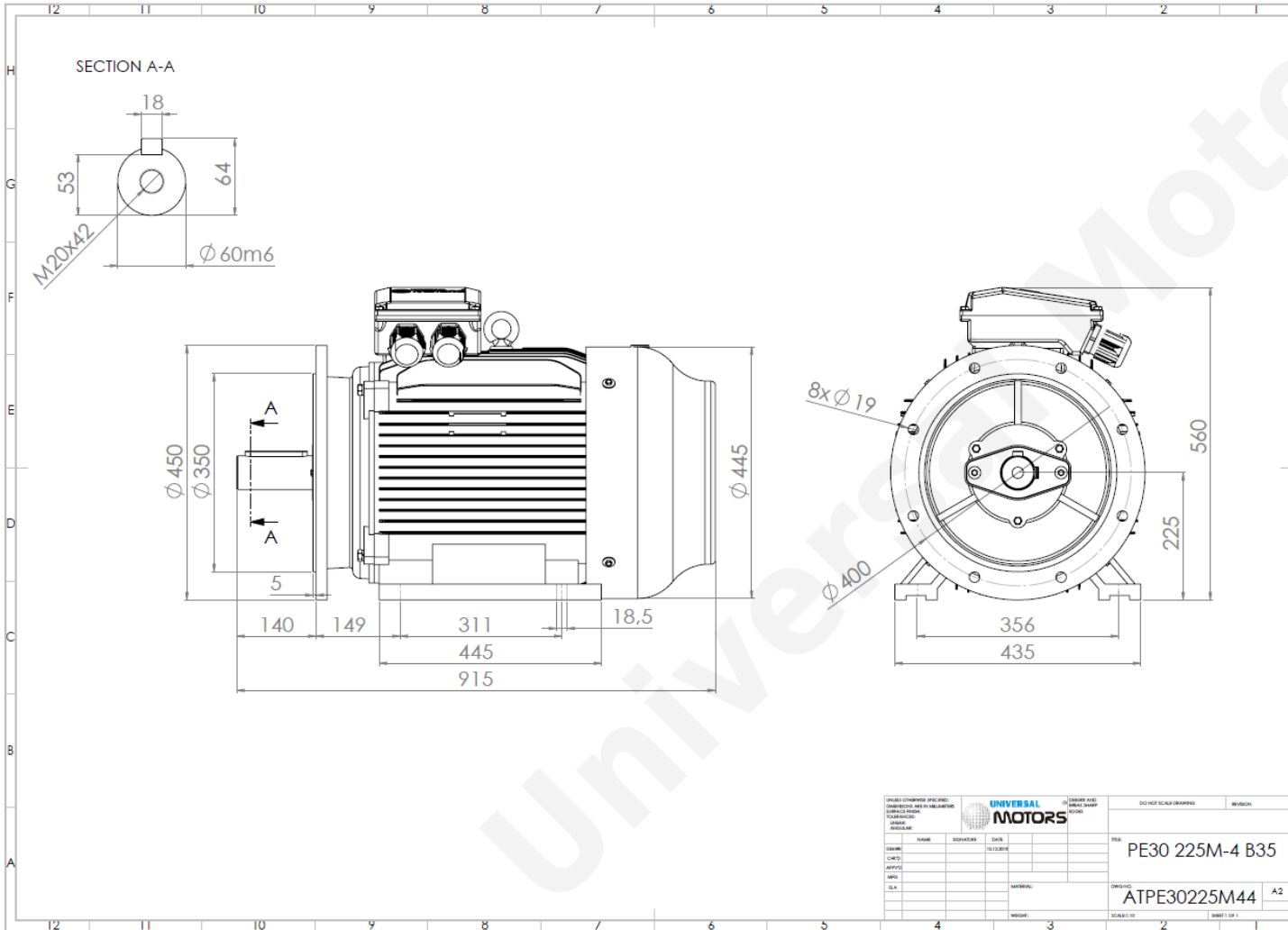

# TECHNICAL DATA

Three Phase Electric Motors - Cast Iron Frame  
 PE30 225M-8  
 22 kW / 30 Cv  
 730 RPM



Motor type:	<b>PE30 225M-8</b>
Output:	<b>22 kW / 30 Cv</b>
Speed (min <sup>-1</sup> ):	<b>730 RPM</b>
Frequency:	<b>50 Hz</b>
Voltage:	<b>400 V</b>
Current:	<b>44.9 A</b>
Power factor (Cos $\varnothing$ ):	<b>0.78</b>
Poles:	<b>8</b>
Insulation class:	<b>F</b>
Temperature rise Class:	<b>B</b>
Efficiency 50%:	<b>89.4 %</b>
Efficiency 75%:	<b>90.9 %</b>
Efficiency 100%:	<b>90.6 %</b>
Torque:	<b>287 N.m</b>
Tstarting/Tnominal:	<b>1.9</b>
Istarting/Inominal:	<b>6.6</b>
Tmaximum/Tnominal:	<b>2.0</b>
Noise:	<b>73 Db(A)</b>
Weight:	<b>334 Kg</b>
Bearing DE:	<b>6313 C3</b>
Bearing NDE:	<b>6313 C3</b>

**Regime - S1**

**Altitude - 1000m**

**Environment Temperature - 40°C**

**CONTACTS:**

UNIVERSAL MOTORS      Tel: +351 252 299 080  
 Rua de São Brás,745      Fax: +351 252 299 089  
 4480-782 VILA DO CONDE      Mail: [geral@universalmotors.pt](mailto:geral@universalmotors.pt)

\* References applied only in the UK